

## LT-3900-700 LED RGB Controller



LT-3900-700 is a multi-function RGB controller that built-in 32 modes. Adopting advanced PWM (Pulse-Width Modulation) control technique, Changing effect is smooth without flicker. Adopting hi-power MOS driver, RGB 3 channels output and total current up to 18A, Unique touch technique, Controller has 8 touch buttons, Which are used for choosing power on or off, pause, modes changed, speed, LED brightness, etc. With an optional IR wireless remote control, which has 12 preset color keys and 7 DIY keys, very user friendly; It can automatically adapt to DC12~48V voltage input, Suitable for major & conventional LED products, Such as LED strip, LED module. Etc. Simply put, As long as low voltage LED lights whose current limited by resistor. Then LT-3900-700 can control.

### 1. Technical Specs

LT-3900-350	
Mating power supply	CV LED Power Supply
Input voltage	DC12V~DC48V
Driving voltage	DC3V~42V
Output current	CC 700mA/CH x3
Driving LEDs	1~12 pcs 3W LED/CH x3
Function Mode	32 modes
Grey scale	256 steps per RGB (8 Bits/CH)
Remote control distance	IR distance: 10m
Working temperature	-30℃~55℃
Product Size	L211×W40×H30(mm)
Packing size	L213×W61×H38(mm)
Weight (G.W.)	220g

1

### 2. Product size

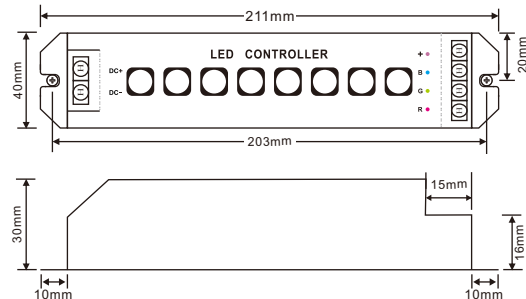

### 3. Detailed key functions

The controller there are 8 function keys

**ON/OFF, PAUSE, MODE+, MODE-, SPEED+, SPEED-, BRT+, BRT-**  
8 press buttons of controller match the 8 formers keys of the remote

Controller sign	Remote control sign	Button	Description
		<b>ON/OFF</b>	<b>ON/OFF:</b> Turn on/off the LED light
		<b>PAUSE</b>	<b>PAUSE</b> Press it to rest at current color. Press it again, it will continue to change
		<b>MODE+ MODE-</b>	<b>MODE+/MODE-</b> Press them to select next mode or back to previous mode Press MODE+ or press MODE- in 3s to enter cycle mode
		<b>SPEED+ SPEED-</b>	<b>SPEED+/SPEED-</b> Press them to quicken or slower speed, press SPEED+ or SPEED- in 3s, current speed is restored to default status
		<b>BRT+ BRT-</b>	<b>BRT+/BRT-</b> Press them to increase or decrease brightness, press any one in 3s, current brightness is restored to default status
		<b>Color choosing</b>	Press the color key, LED lights show the same color
		<b>7 DIY keys</b>	Pressed-in 3s, the controller will save the present changing mode automatically. Can save 7 modes, can be saved repeatedly. Press "PLAY" key to play cycle modes.

2

#### 4. Tables of Changing mode

No.	Mode	Description
1	Static red	brightness adjustable
2	Static green	brightness adjustable
3	Static blue	brightness adjustable
4	Static yellow	brightness adjustable
5	Static purple	brightness adjustable
6	Static cyan	brightness adjustable
7	Static white	brightness adjustable
8	RGB skipping	speed/brightness adjustable
9	7 colors skipping	speed/brightness adjustable
10	White strobe	speed/brightness adjustable
11	7 colors strobe	speed/brightness adjustable
12	Red Fade out and fade in	speed/brightness adjustable
13	Green Fade out and fade in	speed/brightness adjustable
14	Blue Fade out and fade in	speed/brightness adjustable
15	Yellow Fade out and fade in	speed/brightness adjustable
16	Purple Fade out and fade in	speed/brightness adjustable
17	Cyan Fade out and fade in	speed/brightness adjustable
18	White Fade out and fade in	speed/brightness adjustable
19	RGB Fade out and fade in	speed/brightness adjustable
20	Red/green gradual alternately	speed/brightness adjustable
21	Red/blue gradual alternately	speed/brightness adjustable
22	Green/blue gradual alternately	speed/brightness adjustable
23	Red/yellow gradual alternately	speed/brightness adjustable
24	Green/cyan gradual alternately	speed/brightness adjustable
25	Blue/purple gradual alternately	speed/brightness adjustable
26	Green/yellow gradual alternately	speed/brightness adjustable
27	Blue/cyan gradual alternately	speed/brightness adjustable
28	Red/purple gradual alternately	speed/brightness adjustable
29	Blue/white gradual alternately	speed/brightness adjustable
30	Yellow/purple/can gradual alternately	speed/brightness adjustable
31	RGB gradual alternately	speed/brightness adjustable
32	Full color gradual alternately	speed/brightness adjustable

#### 5. Conjunction diagram

1. LT-3900-700 connects 1W hi-power LED directly:

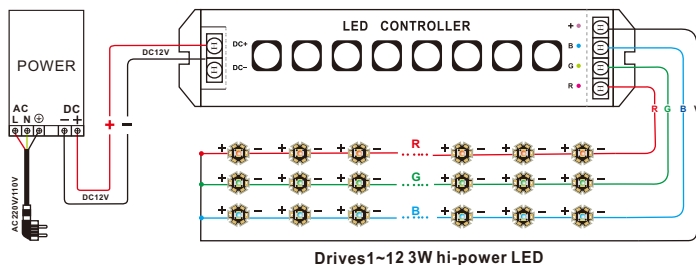

3

Power repeater can be added to amplify power output unlimitedly when the power of one controller is not enough

The following we take RGB module for example, power repeater all are paralleled on the output cable of controller.

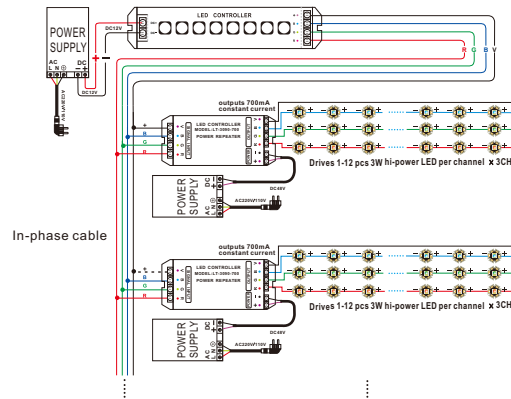

#### 7. Attention

- The product shall be installed and serviced by a qualified person.
- This product is non-waterproof. Please avoid the sun and rain. When installed outdoors please ensure it is mounted in a water proof enclosure.
- Good heat dissipation will prolong the working life of the controller. Please ensure good ventilation.
- Please check if the output voltage of any LED power supplies used comply with the working voltage of the product.
- Please ensure that adequate sized cable is used from the controller to the LED lights to carry the current. Please also ensure that the cable is secured tightly in the connector to avoid the accidents due to overheat and poor contact on the wire.
- Ensure all wire connections and polarities are correct before applying power to avoid any damages to the LED lights.
- If a fault occurs please return the product to your supplier. Do not attempt to fix this product by yourself.

#### 8. Warranty Agreement

- We provide lifelong technical assistance with this product:
  - A 3 year warranty is given from the date of purchase. The warranty is for free repair or replacement and covers manufacturing faults only.
  - For faults beyond the 3 year warranty we reserve the right to charge for time and parts.
- Warranty exclusions below:
  - Any man-made damages caused from improper operation, or connecting to excess voltage and overloading.
  - The product appears to have excessive physical damage.
  - Damage due to natural disasters and force majeure.
  - Warranty label, fragile label and unique barcode label have been damaged.
  - The product has been replaced by a brand new product.
- Repair or replacement as provided under this warranty is the exclusive remedy to the customer. Ltech shall not be liable for any incidental or consequential damages for breach of any stipulation in this warranty.
- Any amendment or adjustment to this warranty must be approved in writing by Ltech only.

★ This manual only applies to this model. Ltech reserves the right to make changes without prior notice.

4